



MMC INTERNATIONAL CORP

# OPERATING AND MAINTENANCE INSTRUCTIONS

**INTRINSICALLY SAFE TRIPLE FUNCTION GAUGING TAPE**

FOR

**OPEN APPLICATIONS**

**LIQUID MEASURE OF ULLAGE, OIL/WATER INTERFACE  
AND TEMPERATURE**

**MODEL D-2401-2**

TECHNICAL APPROVED BY:

FACTORY MUTUAL AND SIRA FOR CLASS I, DIVISION I, GROUPS C & D

AND

LLOYD'S REGISTER AND BUREAU VERITAS "MED" APPROVED

**IN ACCORDANCE WITH IMO RESOLUTION MEPC.5 (XIII)  
FOR OIL/WATER DETECTION**

**MMC INTERNATIONAL CORP.  
60 INIP DRIVE  
INWOOD, NEW YORK 11096**

# **TABLE OF CONTENTS**

	<b>PAGE NUMBER</b>
<b>NOTICES</b>	<b>i</b>
<b>User instructions (in compliance with 2014/34/EU Directive, Annex II, 1.0.6)</b>	<b>ii</b>
<b>MMC Atex/IECEX definition</b>	<b>iii</b>
<b>I. GENERAL</b>	<b>1</b>
1.0 SPECIFICATIONS	1
1.1 LINEAR ACCURACY SPECIFICATIONS	2
1.2 SPECIAL FEATURES	3
<b>II. INTRODUCTION</b>	<b>4</b>
<b>III. THEORY OF OPERATION</b>	<b>5, 6</b>
<b>IV. REQUIRED CONDITIONS AND RECOMMENDATIONS FOR SAFE USAGE</b>	
4.1 REQUIRED CONDITIONS	7
4.2 RECOMMENDED SAFE USAGE CONDITIONS	7
<b>V. OPERATION</b>	
5.1 FAMILIARIZATION WITH OPERATING CONTROLS & FEATURES LOCATED ON THE TAPE REEL HUB COVER	8
5.2 ULLAGE/INTERFACE MEASUREMENTS	8, 9
5.3 TEMPERATURE MEASUREMENT PROCEDURE	10
<b>VI. CARE AND MAINTENANCE</b>	<b>11</b>
<b>VII. CALIBRATION PROCEDURE</b>	
7.1 ULLAGE AND INTERFACE	12
7.2 TEMPERATURE SENSOR CALIBRATION	12, 13
<b>VIII. GAUGING TAPE REPLACEMENT</b>	<b>14, 15</b>
<b>IX. HUB COVER AND P. C. BOARD REPLACEMENT</b>	<b>16</b>

CONTINUED ON NEXT PAGE

**CONTINUED**

<b>X.</b>	<b>FAULT FINDING</b>	17, 18
<b>XI.</b>	<b>APPENDIX</b>	19
<b>XII.</b>	<b>WARRANTY</b>	20
<b>XIII.</b>	<b>GLOSSARY OF APPROVALS</b>	21
<b>IVX.</b>	<b>TEMPERATURE CONVERSION CHART</b>	22
<b>XV.</b>	<b>LIST OF CHEMICALS</b>	23
<b>XVI.</b>	<b>LIST OF DRAWINGS</b>	24

## **NOTICE TO ALL EQUIPMENT USERS**

The triple functions of this sensor are to detect cargo surface level, **Ullage**, the **Interface** between two immiscible products such as oil and water, and cargo **Temperature**.

The normal order of the gauging device, response to the products “Ullage level”, is a steady horn tone. The normal response to an “Interface level”, (i.e., between a non-conducting and an electrically conducting product such as a petroleum product and water, is a “**steady**” tone changing to a “**beeping**” tone at the interface level.

**A special note to our chemical customers, is the fact that some chemical cargoes may be inherently conductive.**

Therefore, at the surface of a conductive product’s Ullage level, a “**beeping**” tone will be the normal response.

As a further note to the above, the change in detection of a non-conductive product Ullage level as a steady tone to that of a conductive product’s ullage “beeping” tone, it is not to conclude that the sensor is malfunctioning.

Best Regards,

MMC International Corp.

## **User instructions (in compliance with ATEX 94/9/EC Directive, Annex II, 1.0.6)**

The following instructions apply to the Flexidip Portable Gauging Tape Type D-2401-2\*\* covered by certificate number BAS 02ATEX1274X. The information contained herein shall be included with every batch of products sold, either as a separate sheet or incorporated as a discrete section in an instruction manual.

**WARNING: USE ONLY DURACELL/PROCELL MN1604 BATTERY REPLACEMENT.  
DO NOT REPLACE BATTERY WHERE AN EXPLOSIVE GAS ATMOSPHERE MAY BE PRESENT.**

**BE AWARE OF POTENTIAL ELECTROSTATIC CHARGING HAZARD AFTER LOADING  
DISTILLED PETROLEUM.**

**THIS DEVICE MUST BE GROUNDED.**

### **Instructions for safe selection, installation, use, maintenance, and repair**

- 1 The equipment may be used in zones 0, 1, or 2 with flammable gases.
- 2 The equipment may be used in the presence of flammable gases and vapors with apparatus groups IIC or IIB or IIA and with temperature classes T1 or T2 or T3 or T4.
- 3 The equipment is certified for use in ambient temperatures in the range of  $-20^{\circ}\text{C}$  to  $+40^{\circ}\text{C}$  and should not be used outside this range.
- 4 The equipment is to be installed by suitably trained personnel in accordance with the applicable code of practice (typically IEC EN 60079-14).
- 5 The equipment does not require assembly or dismantling.
- 6 With regard to safety it is not necessary to check for correct operation.
- 7 No user adjustment is required.
- 8 Regular periodic inspection of the equipment should be performed by suitably trained personnel in accordance with the applicable code of practice to ensure it is maintained in a satisfactory condition.
- 9 The equipment is not intended to be repaired by the user. Repair of the equipment is to be carried out by the manufacturer, or their approved agents, in accordance with the applicable code of practice.
- 10 The equipment contains no other customer-replaceable parts.
- 11 The apparatus shall not be subjected to a prolific charge generating mechanism (such as might occur in pneumatic transfer of powders or charge spraying in a powder coating process).
- 12 If the equipment is likely to come into contact with aggressive substances, e.g., acidic liquids or gases that may attack metals or solvents that may affect polymeric materials, then it is the responsibility of the user to take suitable precautions that prevent it from being adversely affected thus ensuring that the type of protection is not compromised.

## SECTION I

### 1. GENERAL:

#### 1.0 SPECIFICATIONS:

Display Readable Temperature Range	°F = -40° to 199.9°*
*Reading Limit Due to 3-1/3 Digit LCD Display on °F Range	°C = -40° to 150.0°
Guaranteed Temperature Calibration Range (0°C to 88°C)	32°F to 190°F
Accuracy Over Calibration Range	±0.5°F (±0.2°C)
Accuracy Linear Measurements	±1/8" (±2.0 MM), Plus ±0.1% of Total Tape Length, worst case
Minimum Detectable Tank Bottom Liquid Level	3/8" (10MM)
Minimum Detectable Floating Product Level	1/8" (3MM)
Batteries for Intrinsically Safe Operation Only (supplied)	Duracell MN1604
Battery Drain (Temperature Mode)	1.3 ma (In Air) 2.6 ma (In Fluid)
Display	3-1/2 Digit Liquid Crystal Display 1/2" Character Height
Operating Temperature Limit of Liquid Crystal Display,	-40°F to 176°F -40°C to 80°
Storage Temperature Limits	-67°F to 185°F -55°C to 85°C
Available Tape Length	50 FT (15 Meters) 65 FT (20 Meters) 75 FT (25 Meters) 100 FT (30 Meters) 100 FT (10ths & 100ths) 40M
Hazardous Environments	Certified Intrinsically Safe BASEEFA/SIRA, Gas Groups C & D

## 1.1 LINEAR ACCURACY SPECIFICATIONS:

### MMC PORTABLE ELECTRONIC GAUGING TAPE STANDARD PRODUCTION LINEAR MEASUREMENT ACCURACY

<b>Applicable Equipment:</b>	MMC Models D-2401-2 (Trimode), D-2401-2UI (Ullage/Interface)
<b>Tape Lengths:</b>	50FT., 65FT., 75FT., 100FT. and 15M, 20M, 25M, 30M, 40M.
<b>Basic Gauging Tape Style:</b>	Steel, 0.375 wide x 0.006 thick, yellow or white faced, black & red graduation markings. Manufactured in accordance with Federal specification GGG-T-106F.
<b>System Linear Accuracy at 68°F:</b>	English Reading $\pm 1/8"$ of reading plus $\pm 0.01\%$ of total tape length.  Metric Reading $\pm 2\text{MM}$ of reading plus $\pm 0.01\%$ of total tape length.

### GENERAL STATEMENT OF LINEAR ACCURACY

MMC warrants that the above listed, newly produced equipment models, incorporating the listed basic gauging tape style and lengths, will perform to the stated system accuracy.

Certification of accuracy for new equipment is available at an extra cost. Certification costs to standards of accuracy more precise than the stated system accuracy will be quoted upon request.

## **1.2 SPECIAL FEATURES:**

Conductive Tape Surface to Drain Off any Static Charge

Grounding Cable with Heavy Alligator Clamp

Watertight Electronics Construction with Sealed Switches

All Stainless-Steel Fasteners

Nylon Coated Aluminum Reel Housing for Lightweight Portability

Low Battery Display Indicator

High Daylight Visibility with Liquid Crystal Display

Push-Button Night Light

Rapid Multiple Temperature Measurements

IMO Approved for Oil/Water Interface Detection

Full Stow “Pop-up” Button Spring-Loaded Tape Wiper Housing Gas Seal



## SECTION II

### 2.0 INTRODUCTION:

- 2.1 The MMC Tri-Mode portable ullage, temperature and interface tape described herein incorporates extremely accurate instrumentation to provide three vital petroleum and other liquid tank measurements.
- Measurement of surface ullage level of oil or other fluids to an accuracy and repeatability of  $\pm 1/8$  inch.
  - Determination of the exact location of the ullage level of the interface layer exists when an oil-water mixture is contained within the same vessel.
  - Measurement in either Degrees F or Degrees C of the temperature of the fluid within a vessel, at any or several desired ullage levels, in rapid succession. Measurement is given to the nearest 0.1 degree and is accurate to  $\pm 0.2^{\circ}\text{F}$  over the calibrated temperature ranges given in the specifications listed in Section I.
- 2.2 The MMC system utilizes a sensor suspended at the end of a fluoropolymer covered gauging tape wound on a reel assembly. The plastic covered steel gauging tape contains two isolated side conductors to carry the signal and power to the electronic circuit within the sensor barrel with the steel tape, provides the ground return. The plastic surface of the tape has been treated to make it sufficiently conductive to prevent the build-up of static charges. Temperature indication is provided by a large digital liquid crystal display (LCD), housed within a sealed reel driving assembly.
- 2.3 Ullage and interface detection is provided by an audible signal obtained from a horn in the reel driving hub, when the bottom "U" gap in the sonic sensor is immersed in fluid. The audible signal heard will be a continuous tone in a non-conductive fluid such as oil, gasoline, kerosene, etc., but will change to an interrupted tone when immersed in a fluid which is electrically conductive, such as water.
- 2.4 The system is certified as intrinsically safe for electrical equipment in hazardous atmospheres by BASEEFA/SIRA, CSA, BV, DNV.
- 2.5 The triple function temperature, interface, and ullage sensor is powered by a single 9-volt battery contained within the hub assembly. Battery drain is extremely low, (approximately 1-1/4 Milliamperes in either the ullage, interface, or the temperature mode), ensuring very long operation, without battery replacement. Low battery warning is provided at the upper left corner of the temperature display LCD, when the battery voltage has dropped to a level that would, with further operation, cause excessive errors in temperature readings.

## SECTION III

### 3.0 THEORY OF OPERATION:

- 3.1 Drawing D-2562-1FOL illustrates the main components of the Temperature, Ullage, and Interface system. A tape reel contains the calibrated tape. The reel crank on the driving hub is used by the operator to raise and lower the sensing head assembly which is attached to the reel via the tape. Before lowering or raising the tape, the reel brass thumb screw lock must be unlocked.
- 3.2 The sensor head assembly contains two piezo-electric crystals, a pair of interface or conductivity pins and a temperature sensor, located in one of the conductivity pins and electronic circuit board. The sensor is connected electrically to the driving hub electronics by the two wires encased in the gauging tape plastic jacket, which covers and hermetically seals these wires and centers graduated metallic gauging tape. The metallic tape is used as a ground return conductor, which when including the two wires straddling it, form a rectangular three conductor transmission cable.
- 3.3 The electronic circuits in the hub assembly are comprised of an LCD digital display which provides temperature readings when the system is in the temperature mode; an analog to digital converter, a power on-off switch, a mode switch which permits operator to select the temperature mode or ullage/interface mode, a night light switch and ancillary electronic parts all assembled on a printed circuit board. A 9-volt battery power source and audio horn are located within the tape reel hub assembly below the P.C. board of the modular hub cover assembly.
- 3.4 When the system is placed in the ullage/interface mode, and as the sensor is immersed in a non-conductive fluid such as oil, a sonic signal originated by the sensor head circuits freely crosses the sensor gap and is detected, amplified and then transmission tape to the hub electronics board, which in turn drives a horn in the turning drum assembly. A high pitched continuous audible signal is then emitted. When the sonic sensor is in air, the sonic signal does not cross the sensor gap and therefore the horn is silent.
- 3.5 When the sonic sensor is immersed in a conductive fluid, such as the water layer side of an oil/water interface, operation is as above except that the conductivity pins within the sensor gap now permit a minute current to flow between the pins. This current flow is detected by the sensor electronic circuitry with the sensor housing and suitably conditioned to cause the sonic signal to be periodically interrupted, yielding a "beeping" tone for operator identification.
- 3.6 When the system is placed in the temperature mode the ullage and interface circuits within the sensor barrel are de-energized, also disengaging the audio signals associated with the ullage/interface mode. The integrated circuit temperature sensor housed within the grounded interface pin now functions as an extremely accurate linear temperature to current transducer. As the temperature at the sensor rises, so does the temperature sensor current. By passing the temperature sensor current via the transmission tape, through the electronic component network, with the turning drum, input to an A to D converter is caused to vary linearly with temperature. Span control (R18) is adjusted to provide a fixed reference voltage, to scale for either, to scale for either a Centigrade or Fahrenheit reading device. Coded digital output from the A to D converter to the LCD Display is used to provide accurate and fast temperature readings.

The two potentiometer controls, R13 and R18, perform as a two-point temperature calibration adjustment.

A complete temperature calibration procedure is later described in this manual. (See section VIII).

**Temperature recalibration is recommended at yearly intervals.** Please note that units returned for Temperature Calibration during standard or extended warranty periods are not covered by warranty statement.

## SECTION IV

### 4.0 **REQUIRED CONDITIONS AND RECOMMENDATIONS FOR SAFE USAGE:**

The attention of the user of this apparatus is drawn to the possible hazards of ullage, interface, and temperature measurements within flammable liquids, which are known to be generators of static electricity.

Adhering to the specific safety directives of your company is the responsibility of the user. The following is a general guideline to safe usage, drawn from the advice and experience of various industry sources.

The specific safety standards or directives of your company are to be strictly adhered to, with the general guidance given here being regarded as only a supplement to existing and established operating safety procedures.

#### 4.1 **REQUIRED CONDITIONS:**

This apparatus must be earthed (grounded) to the liquid tank containment vessel or tank, before and during introduction into the vessel. The earthed conductor must not be disconnected until the apparatus is completely withdrawn from the vessel being gauged. A suitable grounding cable is provided as part of the gauging unit. Proper grounding of this cable is the responsibility of the user. (See also Page (ii) of this Manual).

#### 4.2 **RECOMMENDED SAFE USAGE CONDITIONS FOR THE TRIPLE FUNCTION GAUGING TAPE:**

- 4.2.1 The grounding of the unit and adhering to the specific company for safety standards or directives, is the sole responsibility of the operator.
- 4.2.2 Sensor entry into tanks or vessel immediately following a tank filling or loading operation of known static accumulator type petroleum products or other such flammable liquids, should not be attempted until at least a period of 30 minutes has elapsed since the cessation of filling.
- 4.2.3 Clean oil distillates are, in general, known to be accumulators of static electricity due to their low conductivity (i.e., less than 100 Pica Siemens/Meter) and therefore may require relaxation periods of longer than 30 minutes before gauging is attempted.
- 4.2.4 The foregoing does not consider the use of anti-static additives to clean oils, as generally easing the need for proper precaution, unless actual and specific product testing has shown the product to have conductivity levels which eliminate the danger of static electric charging.
- 4.2.5 Sensor entry into tanks or vessels that have been water washed and which previously contained, or still partially contain petroleum products is not recommended unless a sounding pipe is provided, and approved for such use, or at least a period of five hours has elapsed since the completion of the working operation.

## SECTION V

### 5.0 OPERATION:

#### 5.1 FAMILIARIZATION WITH OPERATING CONTROLS AND FEATURES LOCATED ON THE TAPE REEL HUB COVER:

- 5.1.1. Turn on power by momentarily depressing the “On/Off” push-button switch (1) located at left of panel. The display should read 1XX.X\* indicating that the system is in the Ullage/Interface mode.
- 5.1.2. Looking at the top left-hand corner of the LCD display, notice if the symbol “LO BAT” appears. If the symbol is displayed, the battery voltage is low, and the battery should be replaced (see Section VII Paragraph 7.5). Always replace the battery if “LO BAT” appears even though the digital display turns on. Temperature readings with a low voltage battery (below 7.0 volts) are unreliable.
- 5.1.3. Once again, momentarily depress the power “On/Off” switch. Note that the display turns off. Always turn power off when the system is not in use to prolong battery life.

Depress the “On/Off” switch once more. Display turns on and reads 1XX.X\* indicating the Ullage/Interface mode.

\*NOTE: Due to an inherent digital uncertainty of the A to D converter, some digital displays, whenever in the Ullage/Interface mode, will read 00.0 instead of 1XX.X.

- 5.1.4. Now momentarily depress the “Mode” switch at the right of the panel. The display should now switch to the temperature mode as indicated by a reading on the display indicative of the temperature of the sensor tip.

Once again depress the “Mode” switch and note that the display reads 1XX.X\* (Ullage/Interface Mode). Depressing the “Mode” switch alternately changes the function from temperature to Ullage/Interface and vice versa. Depressing the power “On/Off” switch alternately turns power off or on regardless of which mode was in operation. However, when power is switched on again the system will always come on in the Ullage/Interface mode.

- 5.1.5. Depress the night light switch (3) at upper center of panel when it is too dark to see the display. The display background will illuminate, and the reading should now be discernible.

#### 5.2 ULLAGE/INTERFACE MEASUREMENTS:

- 5.2.1. If power is off, depress power “On/Off” push-button switch. The system comes on in Ullage/Interface mode (display reads 1XX.X).
- 5.2.2. If the power was on and the system is in temperature mode, depress the “Mode” switch at right of panel to alter function to Ullage/Interface.
- 5.2.3. Make sure “LO BAT” does not show at left upper corner of display.

- 5.2.4 After grounding the assembly, insert the barrel of the gauging unit into the valve. Un-lock the tape reel lock by rotating the brass lock thumbscrew counterclockwise turning position hub seat. Grasp the knurled reel crank hand and lower the sensor head tape assembly, which contains the sonic sensor, into the tank. Always exert a restraining force to prevent the sensor from descending too rapidly or free falling.

**CAUTION!**

Under no circumstances should the reel and tape be permitted to unwind without restraint. Permanent damage may be incurred to the sensor head or to the calibrated tape if the head is permitted to fall freely.

- 5.2.5 Lower the sensor head slowly until a steady tone is heard. If the surface of the fluids is oil or other non-conductive fluid, a continuous audible tone will be heard. If the surface of the fluid is water or other conductive fluid, the audible tone heard will be a “beeping” tone.
- 5.2.6 Define measurement by raising the sensor head until the sound just ceases. Lower until sound is just heard again, to refine ullage level.
- 5.2.7 Place gauging tape against ullage referenced point and read ullage on tape. Note this reading as the surface liquid ullage level.
- 5.2.8 To find the oil-water interface point, continue to lower the sensor into fluid, noting that the audible tone is continuous. When the audible signal changes to a “beeping” tone, the sensor has entered the water column underneath the oil.
- 5.2.9 Raise the sensor very slowly until the tone once again becomes continuous. Repeat if necessary to refine water entry point (Interface level).
- 5.2.10 Again, read the ullage on the tape. By subtracting the first reading obtained (Step 7) from this reading, the total product depth is thus determined. By subtracting the second water level ullage from the maximum tank depth, water level innage is determined.
- 5.2.11 When the measurement is completed, place the spring-loaded wiper knob in the “On” position while rewinding the tape until sensor is stored with the vapor valve entry barrel. Do not close the vapor valve until the fully “stowed” position is confirmed, by noting that yellow pop-up button on top of the wiper housing is up.
- 5.2.12 Lock the reel by rotating the crank/reel lock thumbscrew down position parallel to hub. Depress power “On/Off” switch to conserve battery power.
- 5.2.13 Close the vapor valve, disconnect the valve securing cap, remove the gauging unit, disconnect the grounding cable. Replace the vapor valve cap.

### **5.3 TEMPERATURE MEASUREMENT PROCEDURE:**

- 5.3.1. If power is off, turn unit on by depressing “On/Off” push-button switch. Unit comes on in Ullage/Interface mode. Depress “Mode” push-button switch to select temperature.
- 5.3.2 If unit was on and in Ullage/Interface mode, simply press the “Mode” push-button to select temperature.
- 5.3.3 Make sure “LO BAT” does not show at left upper corner of display. If “LO BAT” appears, replace battery even though the digital display turns on. The display may continue to operate even though the battery voltage is below normal. Temperature reading however, may be in error.
- 5.3.4 Ground the assembly, release the turn handle reel lock. Lower the sensing sensor to the deepest reading desired. Make sure to exert restraining force while lowering.
- 5.3.5 When the desired temperature ullage level is reached, allow the sensor to rest at this point for at least two (2) minutes. Then joggle the sensing sensor up and down, approximately 6” above and below the desired measurement level until the displayed temperature reading settles. Record this reading. For heavy crude oil products, the joggling procedure is a necessity to ensure accurate readings. The viscous nature and low thermal conductivity properties of these petroleum products makes the joggling procedure a necessity to ensure accurate temperature in a minimum amount of time.
- 5.3.6 Raise the sensor to the next ullage level to be measured. Repeat step 5.3.5. Continue raising sensor to all levels at which readings are desired.
- 5.3.7 When the measurements are complete, push “On/Off” button to turn off and conserve battery power. Rewind the tape into the carriage reel assembly. Wipe the tape as it is rewound by placing the spring-loaded wiper in the “On” position.
- 5.3.8 Lock the reel by rotating reel lock crank down, position. Follow the same procedure as described in step 5.2.13.

## SECTION VI

### 6.0 CARE AND MAINTENANCE:

Proper care and maintenance should be practiced to maintain long, trouble free and accurate service and to maximize battery life, as follows:

- 6.1 When not in use, make sure power is off as evidenced by display being extinguished.
- 6.2 Store sensor head assembly in the fully wound position and store in a dry location. Do not allow the instrument to remain for long periods in direct sunlight, or store in temperature above 125° F, or in temperature below freezing. Such temperatures may damage the liquid crystal display.
- 6.3 Wipe excess oil or water from tape, and sensor head. Each time the sensor is raised from the tank, hold the spring-loaded tape wiper switch in the “On” position.
- 6.4 Never permit tape and sensor head to unwind freely (control speed of descent by usage of a restraining force on crank).
- 6.5 **BATTERY REPLACEMENT** (See Approval Label for correct type):

The battery should be replaced whenever the “LO BAT” symbol appears at the upper left corner of the display. If the sensor is used to obtain temperature reading when the battery is low, large errors may result. Always replace battery in a gas free atmosphere. Remove the six machine screws on the hub cover. Lift the cover with its attached P.C. Board. The battery is retained within the reel turning drum by a spring clip battery holder. Remove the battery from the battery cap connector. Replace the battery with a fresh battery of the type listed on the approval label only. Take care to align the Viton cover casket, and machine screw fasteners when re-assembling to tape reel hub.



## SECTION VII

### 7.0 **CALIBRATION PROCEDURE:**

#### 7.1 **ULLAGE:**

The ullage circuits do not require calibration in the field with proper care and handling the equipment should function indefinitely.

#### 7.2 **TEMPERATURE SENSOR CALIBRATION** (Field Operation Only):

The temperature sensor and its associated electronic circuitry have been accurately calibrated at the factory. Temperature calibration by MMC is recommended at twelve-month intervals, with periodic checks being carried out as necessary between these intervals.

Before attempting any calibration, make sure that the battery is at a proper voltage level as evidenced by the fact that "LO BAT" does not appear at the upper left corner of the display when the equipment is powered. Low battery voltage will produce errors in temperature readings. If "LO BAT" appears on the display, check battery voltage and replace. If necessary, calibration of the temperature sensor may be accomplished as follows:

- 7.2.1 Use thermometers accurate to  $\pm 0.1^\circ$  and preferably graduated in one-tenth degree intervals. If mercury thermometers are employed, use two separate thermometers to provide greater resolution. One to cover low temperatures and the other to cover the high temperatures.
- 7.2.2 Remove six machine screws on the hub cover. Lift the cover and attached P.C. Board from Hub exposing two potentiometers at back lower left of board. Lowest potentiometer, marked (R13), is the "Zero" control and the potentiometer to the left and above, marked (R18), is the "span control. (See drawing B-2401-31).
- 7.2.3 Turn display on by depressing power "On/Off" button momentarily. Place system in temperature mode by depressing "Mode" switch. Display should now read temperature at sensor tip.
- 7.2.4 Prepare two temperature baths, a cold bath of approximately one-gallon of water, and a hot bath of approximately one gallon of water at a temperature of at least  $60^\circ$  higher than the cold bath.
- 7.2.5 Place the sensor in the cold bath with thermometer and stir the bath well to equalize temperature. Keep sensor and thermometer together at approximately the same point in the bath.
- 7.2.6 Record: Sensor Cold Reading as = pc (as read from digital display).

Record Reference: Thermometer Cold reading as = tc

- 7.2.7 Repeat the above procedure in a hot bath.
- 7.2.8 Record: Sensor Hot Reading  $as = ph$  (as read from digital display)  
 Record Reference: Thermometer Hot Reading  $as = th$
- 7.2.9 Calculate Zero Correction =  $tc \frac{(ph - pc)}{th - tc} - pc$
- 7.2.10 Place sensor in cold bath. Stir and wait until sensor reading on display stabilizes. Note reading and then adjust “Zero” control potentiometer marked (R13) so that the zero-correction calculated in step 7.2.9 above is added to or subtracted from the sensor reading. If the answer in step 7.2.9 is positive, add the correction, if negative, subtract.
- 7.2.11 Now place thermometer in the cold bath with the sensor and stir. Now adjust the “span” potentiometer until the two readings are equal (the displayed reading, and the reading of reference thermometer).
- 7.2.12 Check readings in hot bath. Slight touch-up of “Span” control may be required. Normally not more than a  $\pm 0.1$  degrees correction is necessary if the calculated measure “Cold” temperature procedure has been performed correctly.

The above method allows the operator to perform the calibration in one step. If desired, and particularly if the error is minor, an adjustment of zero may be performed in the cold bath to equal the thermometer reading. Then the span may be adjusted in the hot bath. However, this procedure requires repetition until both cold and hot bath readings are correct without further adjustment in either cold or hot baths.

## SECTION VIII

### 8.0 GAUGING TAPE REPLACEMENT (With or without new sensor attached):

The gauging tape used for the Trimode restricted gauging system is similar but not interchangeable with the gauging tapes used for closed gauging systems.

The tapes used are bright white faced steel core type, which have been encapsulated with a tefzel jacket. (Tefzel is a registered trade name of the DuPont Corporation). The taps are terminated at the display electronics hub PCB module connection points, by soldered leads within the tape reel internal core. The sensor is connected to the tape by means of a quick connect plug to the tape socket plug.

As with all tefzel coated MMC gauging tapes, the outer surfaces are factory treated to render the surfaces of the tapes with anti-static properties.

The patented process to achieve the desirable anti-static condition is not defeated by tape wiping or cleaning with standard petroleum-based solvents.

Gauging tape replacement is not difficult, but requires careful attention to the travel path of the tape as it exits from the tape reel assembly, passes over the interior guide rollers, cursor pin assembly, anti-chafing rollers and on through the wiper housing.

- 8.1 To replace a tape, remove the machine screws from the hub cover and lay it to the side.
- 8.2 Remove battery from the battery holder, unplug battery cap and storage barrel by loosening cap nuts on wiper housing.
- 8.3 Remove round vapor seal assembly on top of the tape wiper by backing off the Allen set screws which hold it in place and place tape wiper knob in "Off" position.
- 8.4 Completely unreel tape and sensor head. Note that the end of the metallic tape inside the hub is grounded by a machine screw and washer. The tefzel tape cover at this point has been trimmed away to permit good ground contact. Also note that the tape's out conductors are spliced to two of the wires that originated at the circuit board. (Note the color of these wires so that when reassembling, the correct wire will be connected to the top and bottom tape conductors).
- 8.5 Detach the tape at the hub by removing the grounding machine screw and unsolder the splice connections. Pull the tape through the slot in the side of the hub and out through the tape wiper.
- 8.6 Attach a new tape to the hub by reversing the above procedure making sure that the tape numerals face in the same direction as the previous tape numerals faced. Make sure that the splices are well insulated (use shrink tubing) and that the grounding machine screw and washer are fastened tightly to provide a good metallic ground between center ground tape conductor and hub.

- 8.7 Replace battery, battery cap and hub cover. Connect old sensor to tape, if not supplied with replacement. Rewind tape on reel.
- 8.8 Replace tape vapor seal assembly and sensor storage barrel.
- 8.9 Perform a temperature calibration in accordance with Section VII.

## SECTION IX

### 9.0 **HUB COVER AND P.C. BOARD REPLACEMENT:**

To replace the turning drum hub cover and P.C. Board, follow the steps outlined below:

- 9.1 Remove the six machine screws from the hub cover, extract cover, gasket, and P.C. Board.
- 9.2 Unplug battery cap.
- 9.3 Unsolder wires that go to small horn. (Note that these wires originate from the same strip that connects the battery cap).
- 10.4 Now carefully examine three conductor strips that originate at the upper right-hand corner of P.C. board. These wires may not be the same color code as the replacement's hub P.C. Board, and it is important that they be connected to the correct points. Note that one wire (ground) has a terminal lug attached and therefore replaces the previous wire with terminal lug.
- 9.5 Now make a note of the wires that go to top and bottom splices of outer tape conductors. One of these wires goes to a point on the P.C. Board labeled "+V". The other to a point on P.C. Board labeled "SIG". Note which goes to top and which goes to bottom conductor. For example: "SIG" to top connector and "+V" to bottom connector.
- 9.6 Unsolder spliced conductors and remove the nut ground connecting the gauging tape to the driving drum. This now completes disassembly, and the old hub assembly can be put aside.
- 9.7 Position new hub cover and P.C. Board and solder to horn and insulate the two free wires originating from the battery cap strip line. The polarity of these two wires is not important.
- 9.8 Reconnect ground wire with terminal lug to driving drum ground post and replace and tighten nut.
- 9.9 Re-solder and insulate "+V" and "SIG" wire to outer tape conductors taking careful notice of where they originated. (See step 9.5 above)
- 9.10 Replace battery and connect battery cap.
- 9.11 Re-assemble hub cover and attached P.C. Board with six machine screws being careful to line up neoprene gasket.
- 9.12 Perform temperature calibration in accordance with Section VII.

## SECTION X

### 10.0 FAULT FINDING (See Drawing B-2401-31):

The following section covers only simple faults that may occur. No attempt has been made in this section to cover highly technical faults.

PROBLEM NO. 1: Unit does not turn on when power “On/Off” switch is depressed.

PROCEDURE &  
EXPLANATION:

If unit does not turn on at all, check battery voltage using a voltmeter. If battery voltage is lower than four (4) volts, because unit has been accidentally stored for a lengthy period with power on, the voltage is too low to illuminate display. Replace battery. (See Section VII Paragraph 7.5). If battery is okay, check power “On/Off” switch using an OHM meter. Switch should normally show an open circuit. When depressed OHM meter reading should be less than 2 Ohms. If switch is okay, integrated circuit chip is probably at fault. Return to factory or service center for repair.

PROBLEM NO. 2: Unit stays on all the time, even though “On/Off” push-button is depressed.

PROCEDURE &  
EXPLANATION:

This symptom is usually indicative of a faulty power “On/Off” push-button switch. Check the switch with an Ohmmeter as explained in Problem No. 1 above.

PROBLEM NO. 3: Unit turns on and off, however when “Mode” switch is depressed system does not switch to temperature it stays in Ullage/Interface mode always.

PROCEDURE &  
EXPLANATION:

Use OHM meter to make sure “Mode” switch is normally open and when depressed is closed. If switch is faulty, replace. If switch checks out okay, problem is probably an integrated circuit chip. Return to factory for repair.

PROBLEM NO. 4: Temperature readings are erroneous.

PROCEDURE &  
EXPLANATION:

- A) When display is on, does the “LO BAT” appear at the upper left corner? If so, replace battery with a new battery following procedure given in Section VII, Paragraph 7.5.
- B) If “LO BAT” does not appear and display contrast in temperature mode is not good and the decimal point is very faint or not visible, check battery voltage using voltmeter. If voltage has fallen below 5.0 “LO BAT” may not appear. Usually, under these conditions the temperature readings will show extreme errors.
- C) If battery checks out okay, it is possible that the temperature sensor in the sensing head may have been damaged by dropping unit or unit may be out of calibration, due to sever exposure or abuse.

- D) Determine if sensor is still useful by following the calibration procedure given in Section VII.
- E) If fault is not corrected, return to MMC for repair. Sensor or integrated circuit chip may require replacement.

PROBLEM NO. 5: Liquid Crystal Display (LCD) does not function properly one or more segments stay on or off all the time producing strange figures.

PROCEDURE &  
EXPLANATION:

Display contact may be corroded or dirty. Remove hub cover and associated P.C. Board by first removing six machine screws. Remove the three push-button switches and seal boot fasteners. P.C. Board and associated display may now be separated from cover plate. Remove LCD display bezel (see Dwg. B-2401-31) by first removing two machine screws and nuts. Carefully lift bezel and liquid crystal display from blue connector. Make sure that the long thin elastomer contact strips that fit into the top and bottom horizontal slots of the connector are not lost. Remove connector with associated contact strips exposing P.C. Boards contacts. If corroded or dirty, wipe contact (bottom side only) with cotton swab wet with alcohol, being careful not to saturate LCD with fluid.

**CAUTION!**

Do not spray contact cleaner on LCD display or permanent damage may be incurred. Re-assemble in reverse order making sure elastomer contact strips are inserted properly in blue connector horizontal slots. Note that blue connector bottom pins fit into mating hose on P.C. Board for proper alignment. If above procedure does not cure problem, then either display or integrated circuit A/D converter is at fault. Spare display can be substituted to isolate problem. Order from MMC together with new connector.

PROBLEM NO. 6: Display is damaged, permanently discolored, broken.

PROCEDURE &  
EXPLANATION:

Order new display and connector from MMC and follow procedure given in Problem No. 5 to replace.

PROBLEM NO. 7: Unit operated properly in temperature mode, however, when placed in ullage mode, horn does not sound in water, or sound is extremely weak.

PROCEDURE &  
EXPLANATION:

Sonic sensor has probably been damaged by being dropped and replacement may be required. Check unit in a container of clean lube oil, and then in a container of water. If sensor does not respond per operating procedure, then sensor replacement is probably necessary. Return to factory.

## APPENDIX

	PAGE NUMBER
A. MMC Warranty Statement	20
B. Glossary of Approvals	21
C. Temperature Conversion Chart	22
D. List of Corrosive Chemicals	23
E. List of Drawings	24



## WARRANTY

### MMC SONIC ULLAGE, INTERFACE, TEMPERATURE & TRIPLE FUNCTION TAPES:

The seller, MMC or its licensed agents, fully warrants equipment of its manufacture against defects in materials or workmanship for a period of one year from the date of shipment. No other warranty period, in excess of one year, may be expressed or implied by sub-agents or others, unless authorized in writing by MMC. The liability of the seller under this warranty is limited, at seller's option, solely to repair or replace with equivalent equipment.

The seller, upon the expiration of the warranty period, has the option to apply a limited credit, not to exceed the original equipment sales price, toward the purchase of a new piece of equipment, if returned equipment is beyond reasonable repair. In any event, non-warranty repair charges will be quoted to the buyer, for authorization, before repair work commences.

In the event of Returns for Warranty Repairs:

- A. The buyer is to notify the seller in writing upon discovery of the defects.
- B. Upon receipt of written authorization from the seller, the equipment is to be returned as directed, transportation prepaid by the buyer.
- C. Buyer is to disclose the use of this product within hazardous chemical substances. It is the responsibility of the buyer to clean or decontaminate this product before returning for repairs. Buyer's refusal will void repair warranty at seller's option.
- D. If seller's examination of such equipment disclosed to his satisfaction that defects were not caused by negligence, misuse, improper installation, accident or unauthorized repair or alteration by the buyer, repairs will be immediately affected.
- E. Buyer is to provide shipping instructions for the return, including mode of transportation. This warranty does not include mechanical parts failure due to wear or corrosion from normal usage, nor does it cover limited life electrical components or elastomer seals.

This warranty is in lieu of all other warranties, expressed or implied, including that implied of fitness for a particular purpose to the original purchaser or to any other person. Seller shall not be liable for consequential damages of any kind.

### IMPORTANT:

The equipment has been certified as intrinsically safe instrument for only those classes or categories of hazardous areas so stated on the equipment label, bearing the mark of the applicable approval agency. No other usage is implied or otherwise authorized.

Unauthorized repair or component replacement by the user will void this warranty and may affect the intrinsic safety of the equipment.

## **GLOSSARY OF APPROVALS**

MAJOR APPROVAL STANDARDS & GOVERNMENT SPECIFICATIONS  
ADOPTED BY MMC INTERNATIONAL CORP. FOR  
CERTIFICATION, MANUFACTURE, INSPECTION CALIBRATION AND TESTING

### **INTRINSICALLY SAFE APPROVALS**

<b>CAS (CAN.)</b>	Sira Certification Service
<b>CSA</b>	Canadian Standards Association
<b>EECS</b>	Electrical Equipment Certification Service (U.K.)
<b>BV</b>	Bureau of Veritas

### **GOVERNMENT REGULATORY BODIES APPROVALS**

<b>BV</b>	Bureau of Veritas
<b>EECS</b>	Electrical Equipment Certification Service (U.K.)

### **INDUSTRY RECOGNIZED INSPECTION BODIES APPROVALS**

<b>ABS</b>	American Bureau of Shipping
<b>CCS</b>	China Classification Society
<b>DNV</b>	Det Norske Veritas (Norway)
<b>LLOYD'S</b>	Lloyd's of London (U.K.)
<b>NKK</b>	Nippon Kaiji Kyokai (Japan)
<b>RINA</b>	Registro Italiano Navale (Italy)
<b>BV</b>	Bureau of Veritas

### **GAUGING TAPE AND OTHER MEASUREMENT SPECIFICATIONS**

<b>FEDERAL</b>	United States Government Specification
<b>NIST</b>	National Institute of Standards & Technology Test
<b>API</b>	American Petroleum Institute (Partial Adaptation)
<b>ASTM</b>	American Society for Testing Materials

### **PERIODIC FACTORY INSPECTIONS BY REGULATING BODIES**

<b>SIRA</b>	Performs annual inspections for SIRA for equipment approval provisions of directive 2014/34/EU
<b>CSA</b>	CSA performs annual
<b>OSHA</b>	OSHA performs annual inspections (U.S. Government)
<b>BV</b>	Performs annual inspections

## TEMPERATURE CONVERSION CHART

$$C = 5/9 (°F-32) \quad °F = (9/5°C) + 32$$

$$\text{Kelvin} = °C + 273.15 \quad \text{Rankine} = °F + 459.67$$

Table Example:  
 To Convert 1000°C to °F look up to 1000 read left  
 To Convert 1000°F to °C look up to 1000 read right

To °F	From	to °C	to °F	From	to °C	to °F	From	to °C
-0.4	-18	-27.78	165.2	74	23.33	323.6	162	72.22
+3.2	-16	-26.67	168.8	76	24.44	327.2	164	73.33
+6.8	-15	25.56	172.4	78	25.56	330.8	166	74.44
+10.4	-12	-23.33	176.0	80	26.67	334.4	168	75.56
+17.6	-8	-22.22	179.6	82	27.78	338.0	170	76.67
+21.2	-6	-21.11	183.2	84	28.89	341.6	172	77.78
+24.8	-4	-20.00	186.8	86	30.00	345.2	174	78.89
+32.0	+0	-17.78	190.4	88	31.11	348.8	176	80.00
+35.6	+2	-16.67	194.0	90	32.22	352.4	178	81.11
+39.2	+4	-15.56	197.6	92	33.33	356.0	180	82.22
+42.8	+6	-14.44	201.2	94	34.44	359.6	182	83.33
+46.4	+8	-13.33	204.8	96	35.56	363.2	184	84.44
+50.0	+10	-12.22	208.4	98	36.67	366.8	186	85.56
+53.6	+12	-11.11	212.0	100	37.78	370.4	188	86.67
+57.2	+14	-10.00	215.6	102	38.89	374.0	190	87.78
+60.8	+16	-8.89	219.2	104	40.00	377.6	192	88.89
+64.4	+18	-7.78	222.8	106	41.11	381.2	194	90.00
+68.0	+20	-6.67	226.4	108	42.22	384.8	196	91.11
+71.6	+22	-5.56	230.0	110	43.33	388.4	198	92.22
+75.2	+24	-4.44	233.6	112	44.44	392.0	200	93.33
+78.8	+26	-3.33	237.2	114	45.56	395.6	202	94.44
+82.4	+28	-2.22	240.8	116	46.67	399.2	204	95.56
+86.0	+30	-1.11	244.4	118	47.78	402.8	206	96.67
+89.6	+32	0.00	248.0	120	48.89	406.4	208	97.78
+93.2	+24	+1.11	251.6	122	50.00	410.0	210	98.89
+96.8	+36	+2.22	255.2	124	51.11	413.6	212	100.00
+100.4	+38	+3.33	258.8	126	52.22	435.2	214	101.11
+104.0	+40	+4.44	262.4	128	53.33	438.8	216	102.22
107.6	42	5.56	266.0	130	54.44	442.4	218	103.33
111.2	44	6.67	269.6	132	55.56	446.0	220	104.44
114.2	46	7.78	273.2	134	56.67	449.6	222	105.56
118.4	48	8.89	276.8	136	57.78	453.2	224	106.67
122.0	50	10.00	280.4	138	58.89	456.8	226	107.78
125.6	52	11.11	284.0	140	60.00	460.4	228	108.89
129.2	54	12.22	287.6	142	61.11	464.0	230	110.00
132.8	56	13.33	291.2	144	62.22	467.6	232	111.11
136.4	58	14.44	294.8	146	63.33	471.2	234	112.22
140.0	60	15.56	298.4	148	64.44	474.8	236	113.33
143.6	62	16.67	302.0	150	65.56	478.4	238	114.44
147.2	64	17.78	305.6	152	66.67	482.0	240	115.56
150.8	66	18.89	309.2	154	67.78	485.6	242	116.67
154.4	68	20.00	312.8	156	68.89	492.8	244	117.78
158.0	70	21.11	316.4	158	70.00	496.4	246	118.89
161.6	72	22.22	320.0	160	71.11	500.0	248	120.00

## LIST OF CHEMICALS

The following list of chemicals, although not all-inclusive, are known to attack PES, the material from which a portion of the sonic liquid level sensor is made.

Prolonged submergence of the sensor should be avoided.

After submergence in any of these chemicals, a thorough cleaning of the sensor head should be conducted to prolong sensor life.

\*ACETALDEHYDE –  $\text{CH}_3\text{CHO}$

\*ETHYL ACETATE –  $\text{CH}_3\text{COOC}_2\text{H}_5$

\*ACETONE –  $\text{CH}_3\text{CHOH}_2$

\*ETHYLENE GLYCOL –  $\text{HOC}_2\text{H}_4\text{OH}$

\*ANILINE –  $\text{C}_6\text{H}_5\text{CL}$

\*METHYL ETHYL KETONE –  $\text{C}_2\text{H}_5\text{COCH}_3$

BENZALDEHYDE –  $\text{C}_6\text{H}_5\text{CL}$

\*METHYLENE CHLORIDE –  $\text{CH}_2\text{CL}_2$

CHLOROBENZENE –  $\text{C}_6\text{H}_5\text{CL}$

NITRO BENZENE –  $\text{C}_6\text{H}_5\text{NO}_2$

CRESOL –  $\text{CH}_3\text{C}_6\text{H}_4\text{OH}$

\*PHENOL –  $\text{C}_6\text{H}_5\text{OH}$

\*CYCLOHEXANONE –  $\text{C}_6\text{H}_{10}\text{O}$

\*PYRIDINE –  $\text{C}_5\text{H}_5\text{N}$

DICHLOROBENZENE –  $\text{C}_6\text{H}_4\text{CL}_2$

TOLUENE –  $\text{C}_6\text{H}_5\text{CH}_3$

1,2 DICHLORETHANE –  $\text{CH}_2\text{CLCH}_2\text{CL}$

TRICHLOROETHYLENE –  $\text{CLCH}=\text{CCL}_2$

\*These chemicals are known to be water soluble, ranging from very to slightly; while this information is useful in sensor cleaning procedure, it will also make interface readings less accurate. In such case, good interface readings will depend upon the relative specific gravities involved. In the extreme case of dissolved water within a cargo, and upon ullage gauging of these chemicals, a beeping tone will be heard instead of the normal steady horn tone. This sensor response should not be interpreted as a malfunctioning unit.

**LIST OF DRAWINGS**

**“OPEN TAPE”**

<b><u>DRAWING NUMBER</u></b>	<b><u>REV.</u></b>	<b><u>DESCRIPTION</u></b>
B-2401-31	A	P.C. Board Component Placement & LCD Assembly
B-2401-72B	C	Sub-Assembly, Hub Cover plate and P.C. Board, Factory Mutual & BASEEFA
D-2562-1FOL	-	Portable FlexiDip UI Gauging Open Application

UNAUTHORIZED USE, MANUFACTURE OR REPRODUCTION IN WHOLE OR IN PART IS PROHIBITED. DRAWING, DESIGN AND OTHER DISCLOSURES PROPERTY OF MMC INTERNATIONAL CORP. INWOOD L.I. NEW YORK

REVISIONS			
SYM.	DESCRIPTION	DATE	APP'D
A	CONVERTED TO CAD FORMAT U1 & L2 MOVED TO PCB TOP SIDE, PT#9 (LED REFLECTOR) DELETED	7-99	FSG

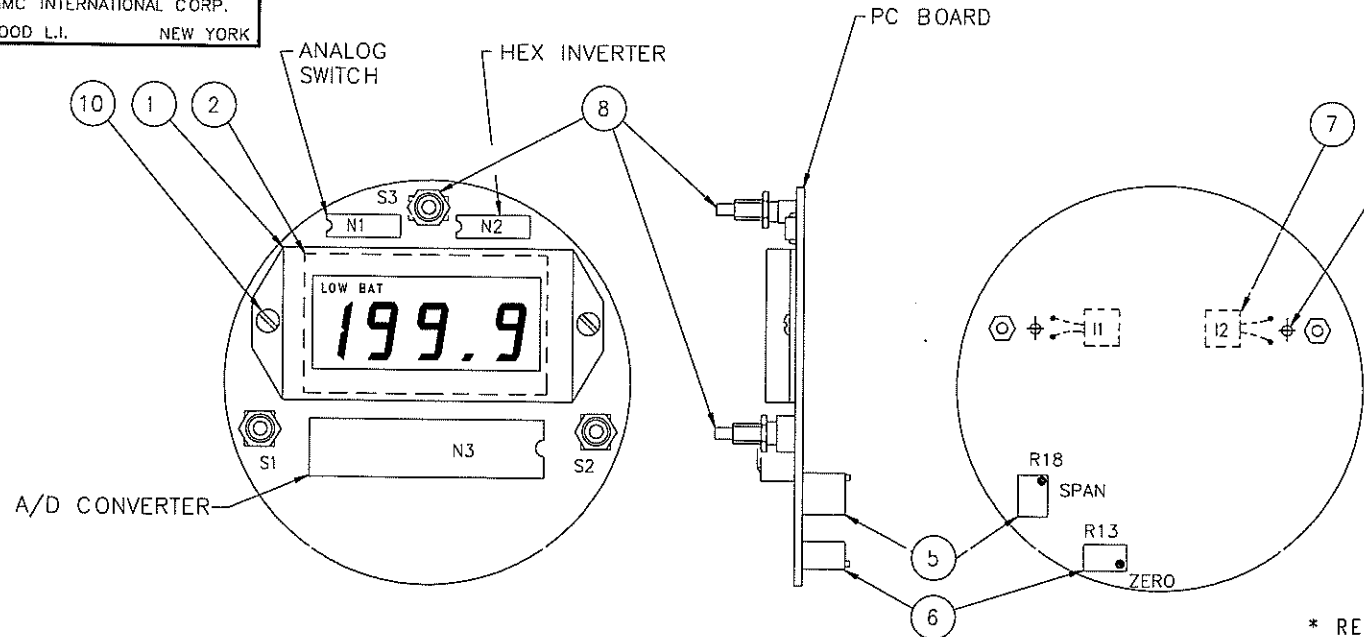

**CERTIFIED PRODUCT DWG.**  
 Fielded/Approval Type  
 NO MODIFICATIONS PERMITTED  
 WITHOUT PRIOR APPROVAL  
 OF AUTHORIZED PERSON  
 CHIEF ENG. FSG  
 ISSUE DATE: 7/6/99

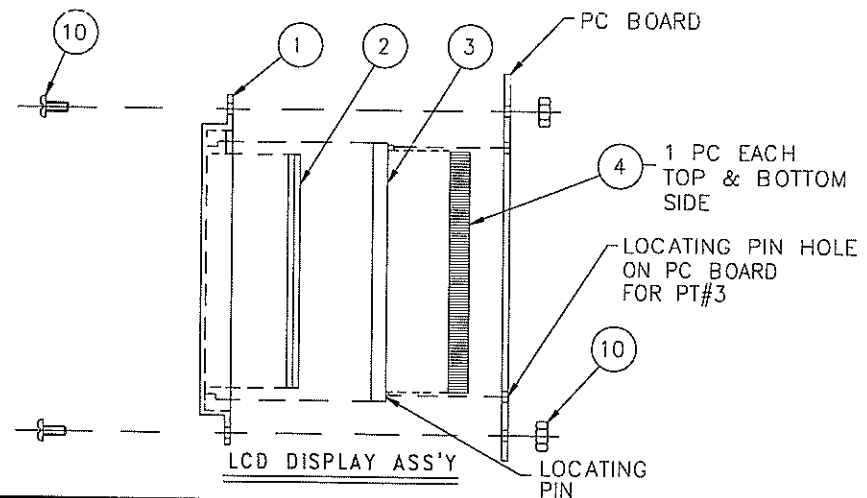

\* REPLACEABLE PARTS

SYM	REQD	PART NO.	REF	DESCRIPTION	MAT'L
	2ea	10	16 2401 2	SCR,W,PAN IID #2-56 X 9/32LG, HEX NUT #2-56	STN. STL
		9			
S1, S2, S3	3	8	5-2401-32	SWITCH, PUSHBUTTON, N.O. SUBMINIATURE	1/4-40 THD
I1, I2	2	7	5-2402-8	LED, WHITE FLAT	PLASTIC
R13	1	6	5-2401-31	POTENTIOMETER, 100K (ZERO)	CERMET
R18	1	5		POTENTIOMETER, 100K (SPAN)	CERMET
	2	4	16-2401-3	ZEBRA CONNECTOR STRIP, 20 CONTACTS	CONDUCTIVE ELASTOMER
	1	3		RETAINER, ZEBRA CONNECTOR	PLASTIC
	2	2	5-2401-9	LCD DISPLAY, 3 1/2 DIGITS, DUAL IN-LINE	GLASS
	1	1	7-2272-3	LCD DISPLAY HOLDER	PLASTIC

DIMENSIONAL TOLERANCES UNLESS OTHERWISE SPECIFIED			<b>TRIMODE PC BOARD          COMPONENT PLACEMENT          &amp; L.C.D. ASSEMBLY</b>		MMC INTERNATIONAL CORP. INWOOD L.I. NEW YORK	
FRAC.	DEC.	ANG.			DWG. NO.	REV.
± 1/64	± .005	± 30'	SCALE FULL	NO. REQ'D.	DRAWN P.E. DATE 3/12/84	<b>B-2401-31</b>
NEXT D-2401-15 & ASSY. D-2401-17			CHECKED	DATE		
			APPROVED	DATE		

UNAUTHORIZED USE, MANUFACTURE OR REPRODUCTION IN WHOLE OR IN PART IS PROHIBITED  
DRAWING, DESIGN AND OTHER DISCLOSURES PROPERTY OF

MMC INTERNATIONAL CORP.

INWOOD L.I. NEW YORK

**NOTES:**

- FACTORY MUTUAL NAMEPLATE USED ON DWGS. D-2562-1FRL AND D-2562-1FOL  
CSA/SIRA NAMEPLATE USED ON DWGS. DB-2562-1FRL AND DB-2562-1FOL

REVISIONS			
SYM.	DESCRIPTION	DATE	APP'D
A	ORIGINAL SCANNED & COVERED TO CAD FORMAT	1/99	FSG
B	UPDATED TO ATEX IIC APP'L	8/11	FSG
C	UPDATED TO LATEST ATEX STANDARDS	7/22	C.E.

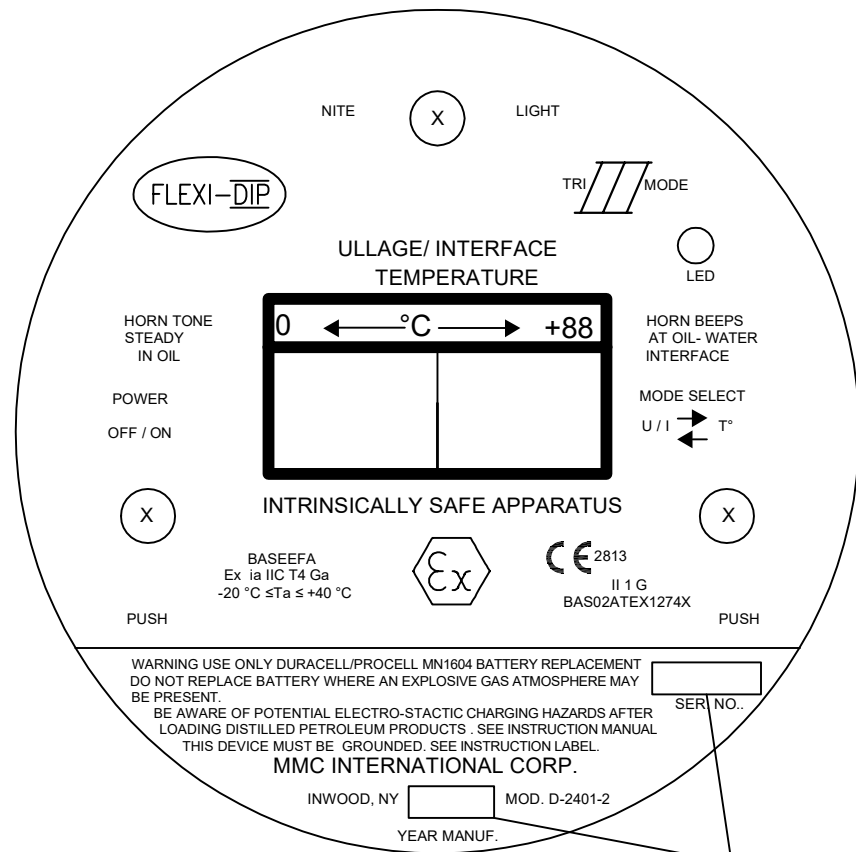

GOLD FILED BOXES

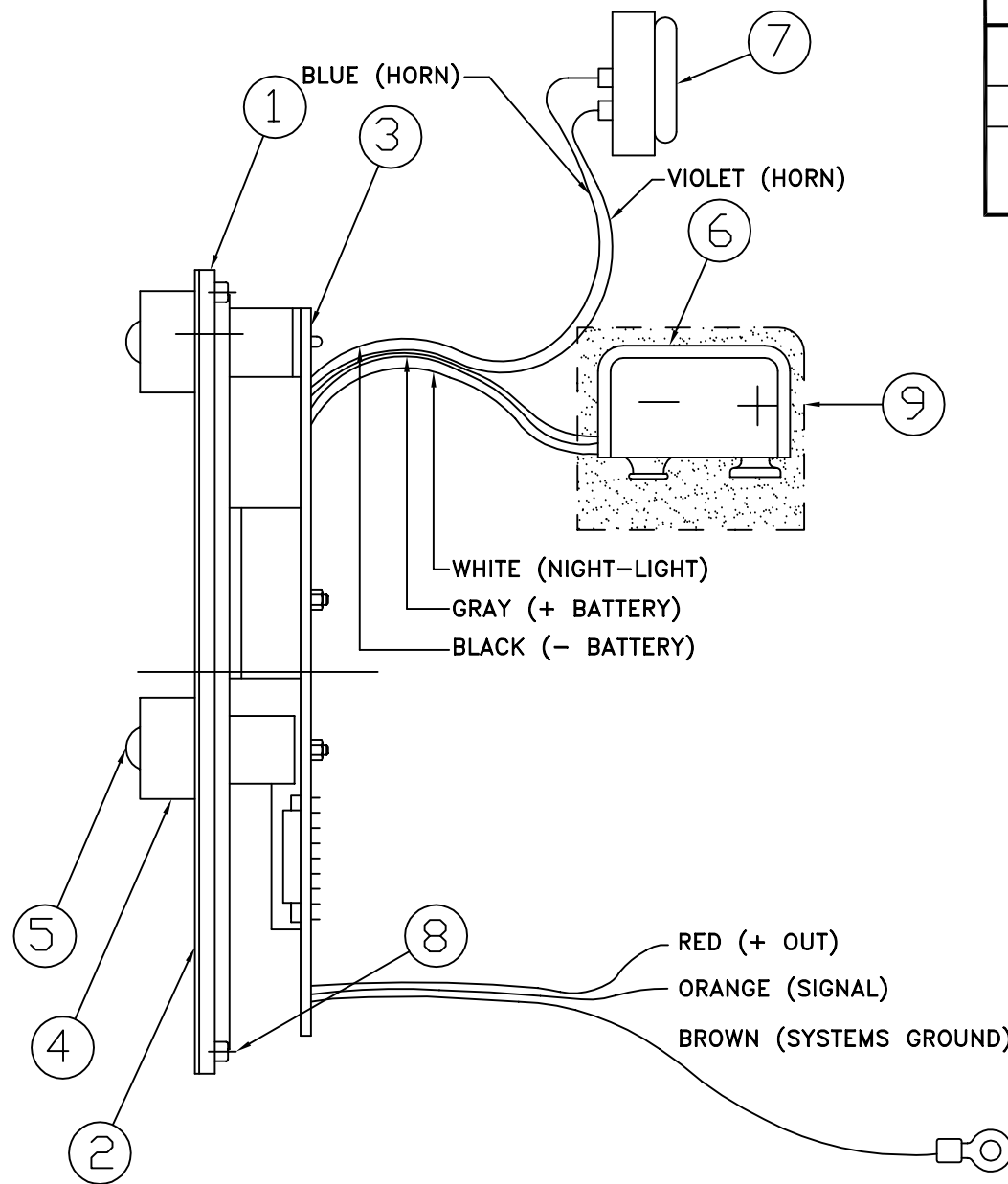

SIRA ATEX APPROVAL LABEL

PART # 2

REQ'D	PT.#	DWG. NO.	DESCRIPTION	MAT'L.
1	9		BATTERY BOOT	VINYL
1	8		"O"- RING, PARKER # S-155	BUNA-N
1	7	A-2401-63	HORN, PIEZO ELEC. SUB-ASS'Y.	EFBRD24C41
1	6	B-2401-15	BATTERY, CONNECTION CAP	POTTED
3	5	AMR N-5040-R	PUSH BUTTON SEAL CAP	BUNA-N
3	4	A-2272-17	PUSH BUTTON GUARD	ALUM
1	3	B-2401-3	HUB, SMT PC BOARD, TRIPLE	1/16, FR4
1	2	AS SHOWN	NAME PLATE, HUB TRIPLE HAND TAPE	ALUM./MYLAR
1	1	A-2455-13	HUB, FACEPLATE	LEXAN

DIMENSIONAL TOLERANCES UNLESS OTHERWISE SPECIFIED			TITLE SUB-ASSY HUB COVERPLATE & PCB (TRIPLE FUNCTION)		MMC INTERNATIONAL CORP. INWOOD L.I. NEW YORK	
FRAC	DEC	ANG.				
= 1/64	± .005	± 30'	DRAWN L. CORRADO DATE 11/87		DWG NO.	REV.
SCALE FULL NO REQ'D			CHECKED DATE		B-2401-72	C
NEXT ASSY. SEE NOTES			APPROVED F.S.GIANNONE DATE			

REVISIONS			
REV.	DESCRIPTION	DATE	BY

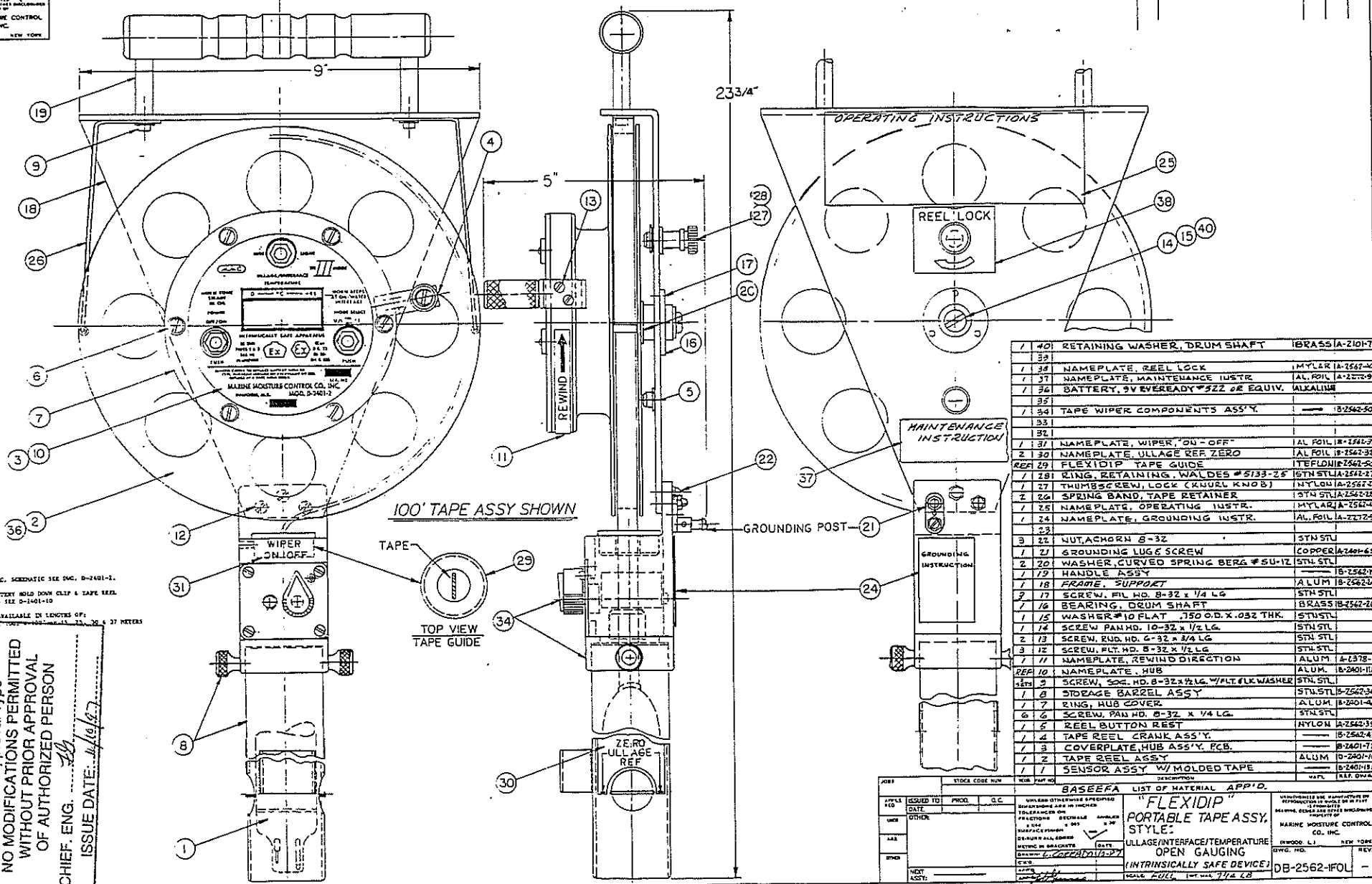

1	40	RETAINING WASHER, DRUM SHAFT	BRASS 1A-21017
1	38	NAMEPLATE, REEL LOCK	MYLAR 1A-2547-40
1	37	NAMEPLATE, MAINTENANCE INSTR.	AL. FOIL 1A-2172-9
1	36	BATTERY, 9V EVEREADY #322 OR EQUIV.	ALKALINE
1	34	TAPE WIPER COMPONENTS ASS'Y.	1B-2542-50
1	33		
1	32		
1	31	NAMEPLATE, WIPER, 'ON-OFF'	AL. FOIL 1B-2542-32
2	30	NAMEPLATE, VULLAGE REF. ZERO	AL. FOIL 1B-2542-30
2	29	FLEXIDIP TAPE GUIDE	ITE FLOIDIP 2542-29
1	28	RING, RETAINING, WAL DES #5133-25	15TH STL 1A-2542-28
1	27	THUMBSCREW, LOCK (KNUCKLE KNOB)	1N TLOW 1A-2542-27
2	26	SPRING BAND, TAPE RETAINER	15TH STL 1A-2542-26
1	25	NAMEPLATE, OPERATING INSTR.	MYLAR 1A-2542-25
1	24	NAMEPLATE, GROUNDING INSTR.	AL. FOIL 1A-2172-9
1	23		
3	22	NUT, CHORN 8-32	15TH STL
1	21	GROUNDING LUG SCREW	COPPER 1A-2401-65
2	20	WASHER, CURVED SPRING BERG #SU-12	15TH STL
1	19	HANDLE ASSY	1B-2542-19
1	18	FRAME, SUPPORT	ALUM 1B-2542-18
2	17	SCREW, FIL HD. 8-32 x 1/4 LG	15TH STL
1	16	BEARING, DRUM SHAFT	BRASS 1B-2542-16
1	15	WASHER #10 FLAT .150 O.D. X .032 THK.	15TH STL
1	14	SCREW, PAN HD. 10-32 x 1/2 LG	15TH STL
2	13	SCREW, RUD. HD. 6-32 x 3/4 LG	15TH STL
3	12	SCREW, FLT. HD. 8-32 x 1/2 LG	15TH STL
1	11	NAMEPLATE, REWIND DIRECTION	ALUM 1A-1378-1
REP	10	NAMEPLATE, HUB	ALUM 1B-2401-11A
1	9	SCREW, PAN HD. 8-32 x 1/2 LG W/FLT. LK WASHER	15TH STL
1	8	STORAGE BARREL ASSY	15TH STL 1B-2542-34
1	7	RING, HUB COVER	ALUM 1B-2401-40A
6	6	SCREW, PAN HD. 8-32 x 1/4 LG	15TH STL
1	5	REEL BUTTON REST	NYLON 1A-2542-39
1	4	TAPE REEL CRAWK ASS'Y.	1B-2542-43
1	3	COVERPLATE, HUB ASS'Y. PCB.	1B-2401-72
1	2	TAPE REEL ASSY	ALUM 1B-2401-70
1	1	SENSOR ASSY W/ MOLDED TAPE	1B-2401-19A

QTY	ISSUED TO	PROD.	Q.C.	STOCK CODE NUM	WGR	DATE	DESCRIPTION	WFL	REF. DWG.

BASEEFA LIST OF MATERIAL APP'D.

"FLEXIDIP" PORTABLE TAPE ASSY, STYLE: VULLAGE/INTERFACE/TEMPERATURE OPEN GAUGING (INTRINSICALLY SAFE DEVICE)

SCALE: FULL, 1/2" = 1'-0"

DB-2562-1FOL

CERTIFIED PRODUCT DWG.  
 Related/Approval Type  
 NO MODIFICATIONS PERMITTED  
 WITHOUT PRIOR APPROVAL  
 OF AUTHORIZED PERSON  
 CHIEF. ENG. *[Signature]*  
 ISSUE DATE: 11/16/67